

Stojany a modulární montážní držáky a redukční desky

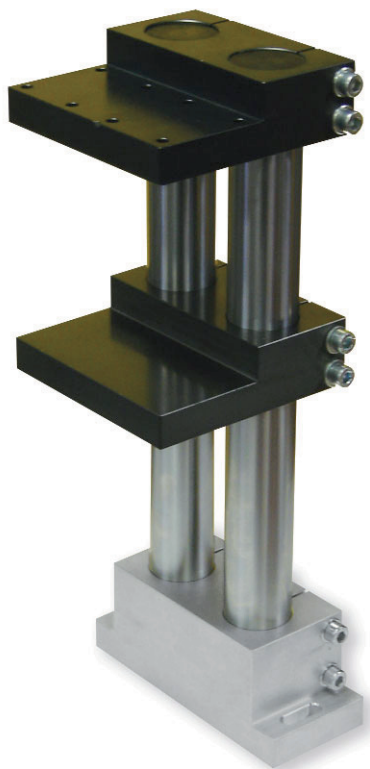

K dosažení maximální úrovně obsluhy přesných dynamických ovládacích systémů je nezbytná robustní, vibračním odolná, podpůrná konstrukce. Pouze s takovou konstrukcí je možné využít přesnosti při vysokém počtu opakování a rychlosti jednotlivých součástek.

Naše broušené a chromované jednoduché a dvojitě hřídele umožňují přesné, jednoduché upnutí a seřízení montážních desek a příčných spojek. Použitím těchto standardních modulárních součástí se může snadno upravit široký rozsah montážních nastavení.

Vlastnosti výrobku:

- Chromované hřídele, průměr 40 mm
- Standardní délka, možná i uživatelská délka
- Jednoduchost, přesnost a bezpečnost
- Snadné nastavení výšky
- Bez nutnosti projektování, použijte standardní modulární montážní díly
- Přesné součástky
- Šedě eloxované montážní díly
- Při objednávce 20 a více kusů si můžete zvolit barvu - černá, červená, zelená, modrá, fialová nebo zlatá

Použití:

SE01.002

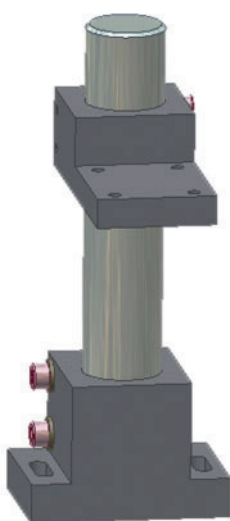

SE01.010

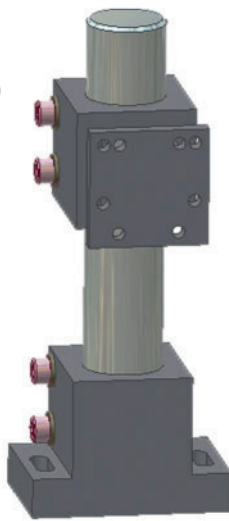

SD01.002

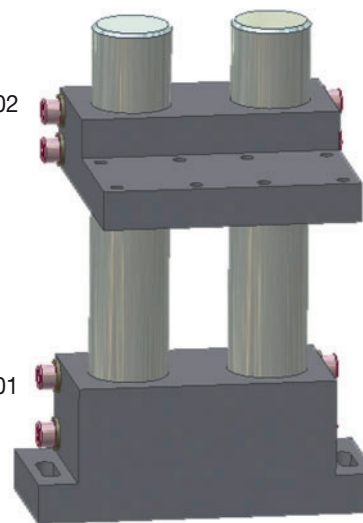

SE01.001

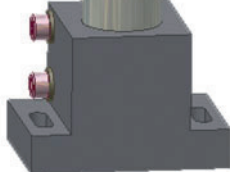

SE01.001

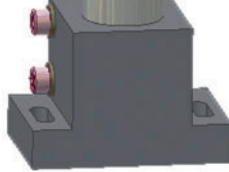

SD01.001





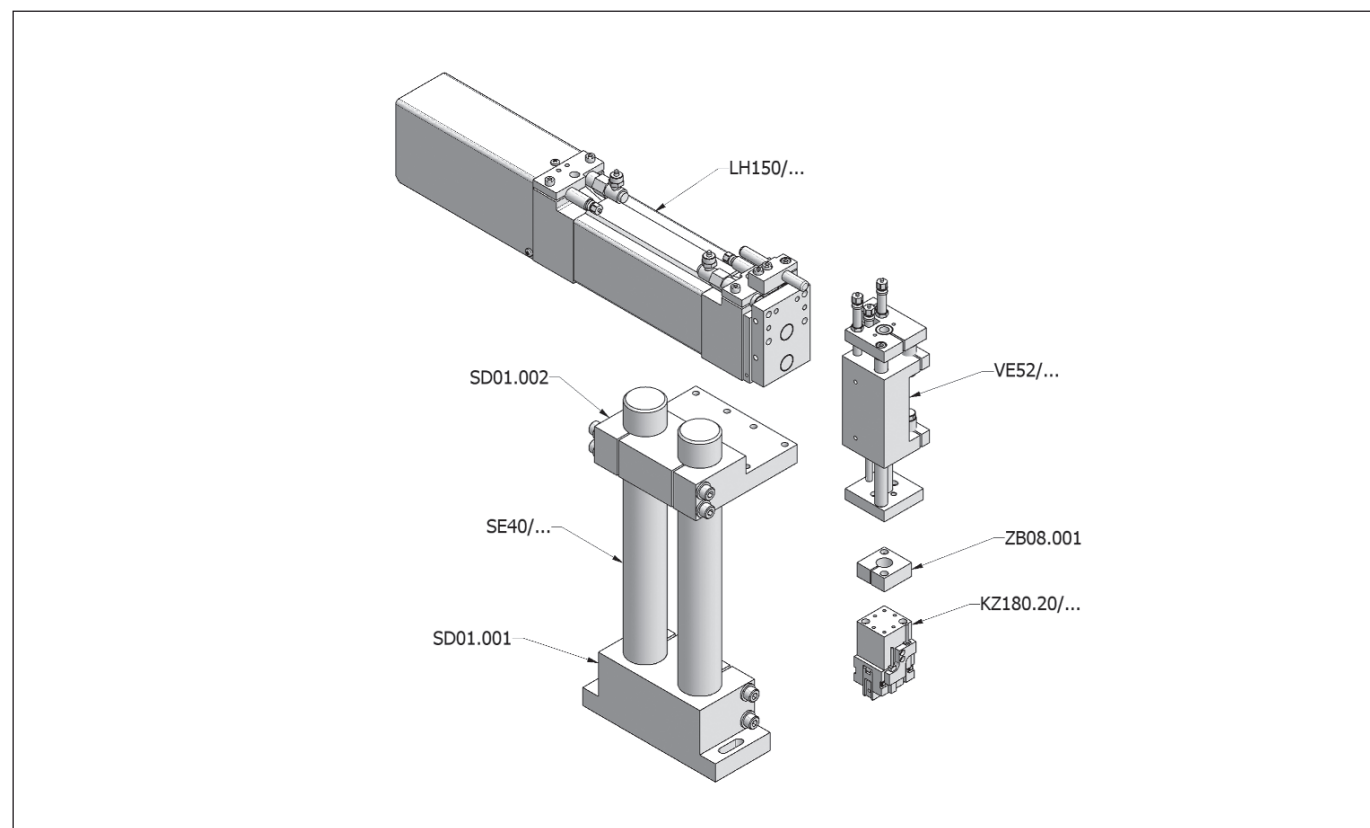
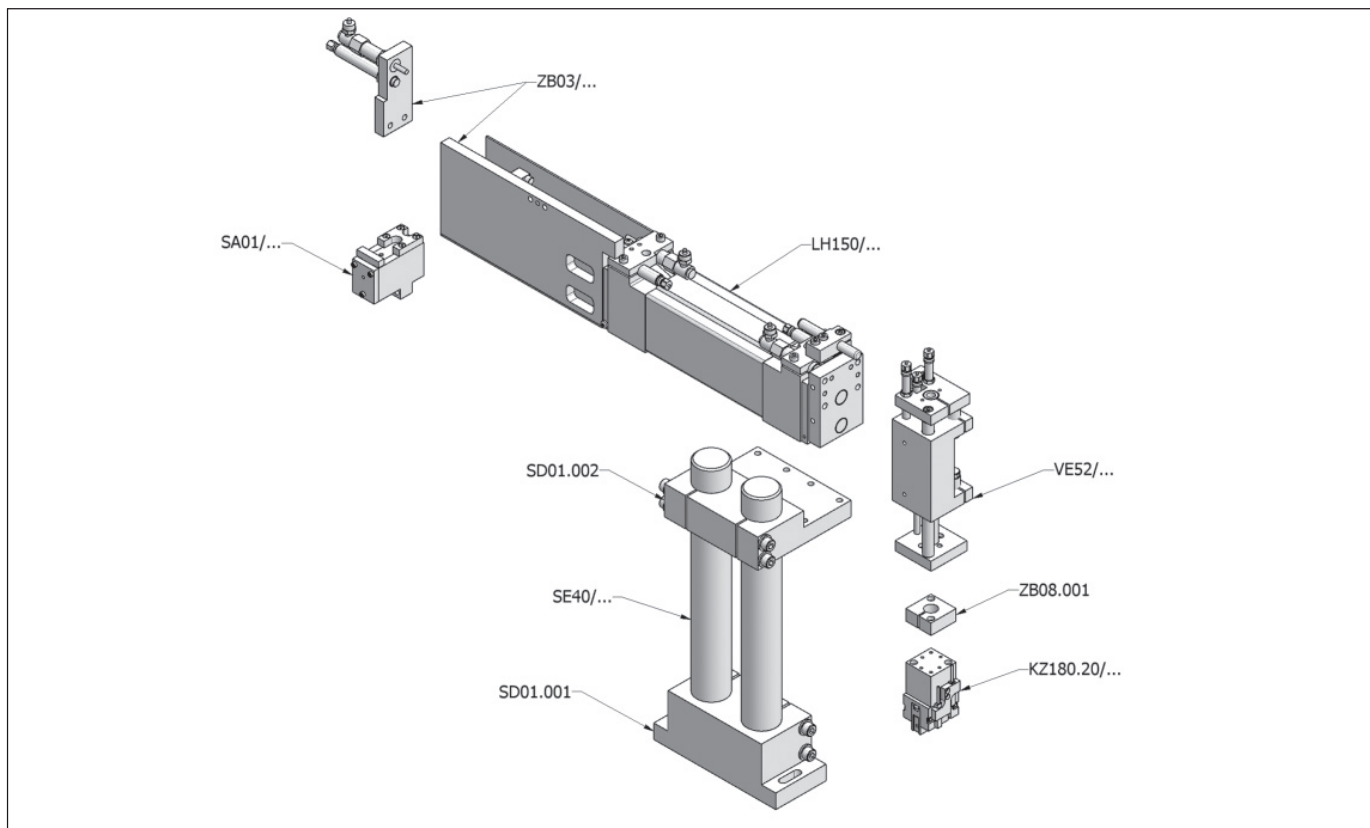

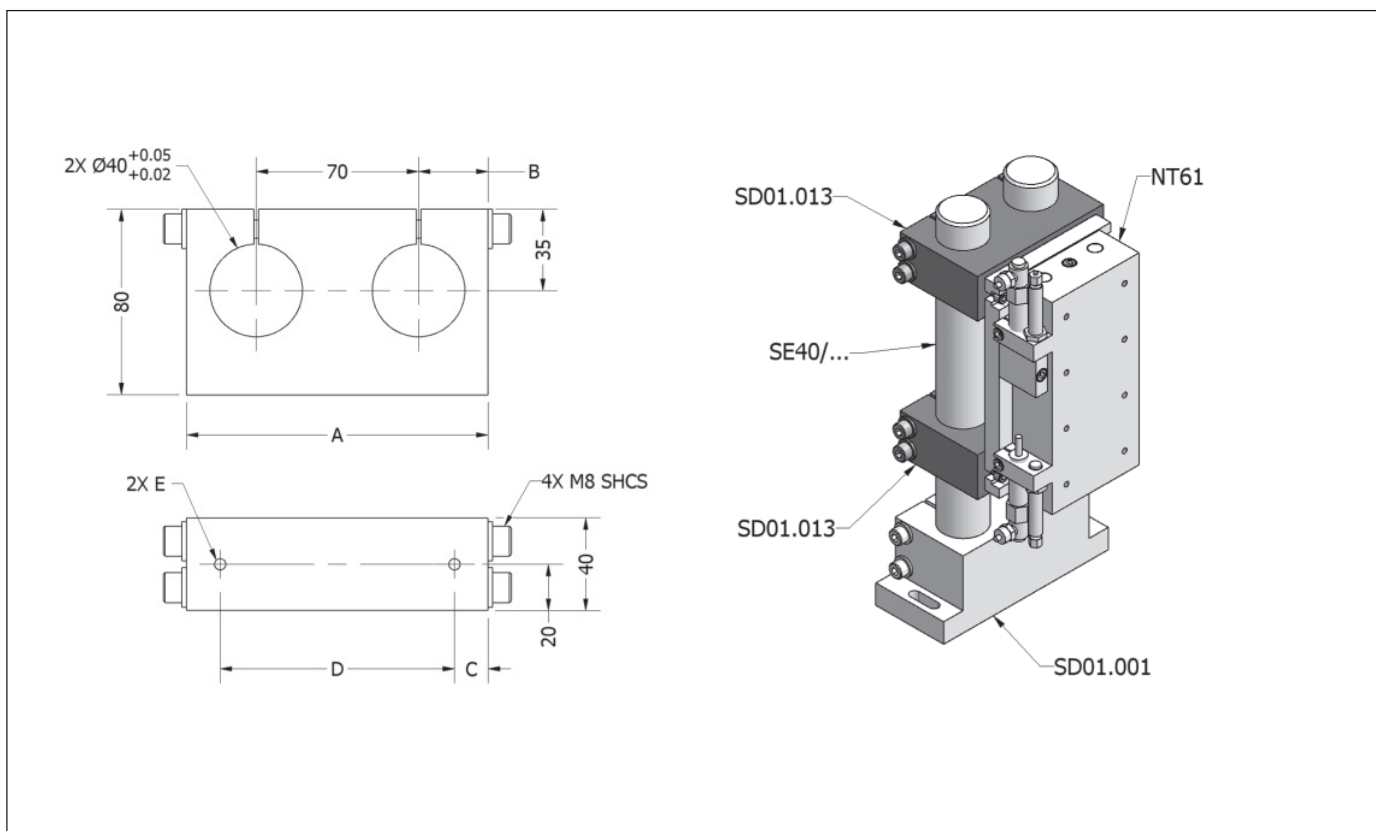
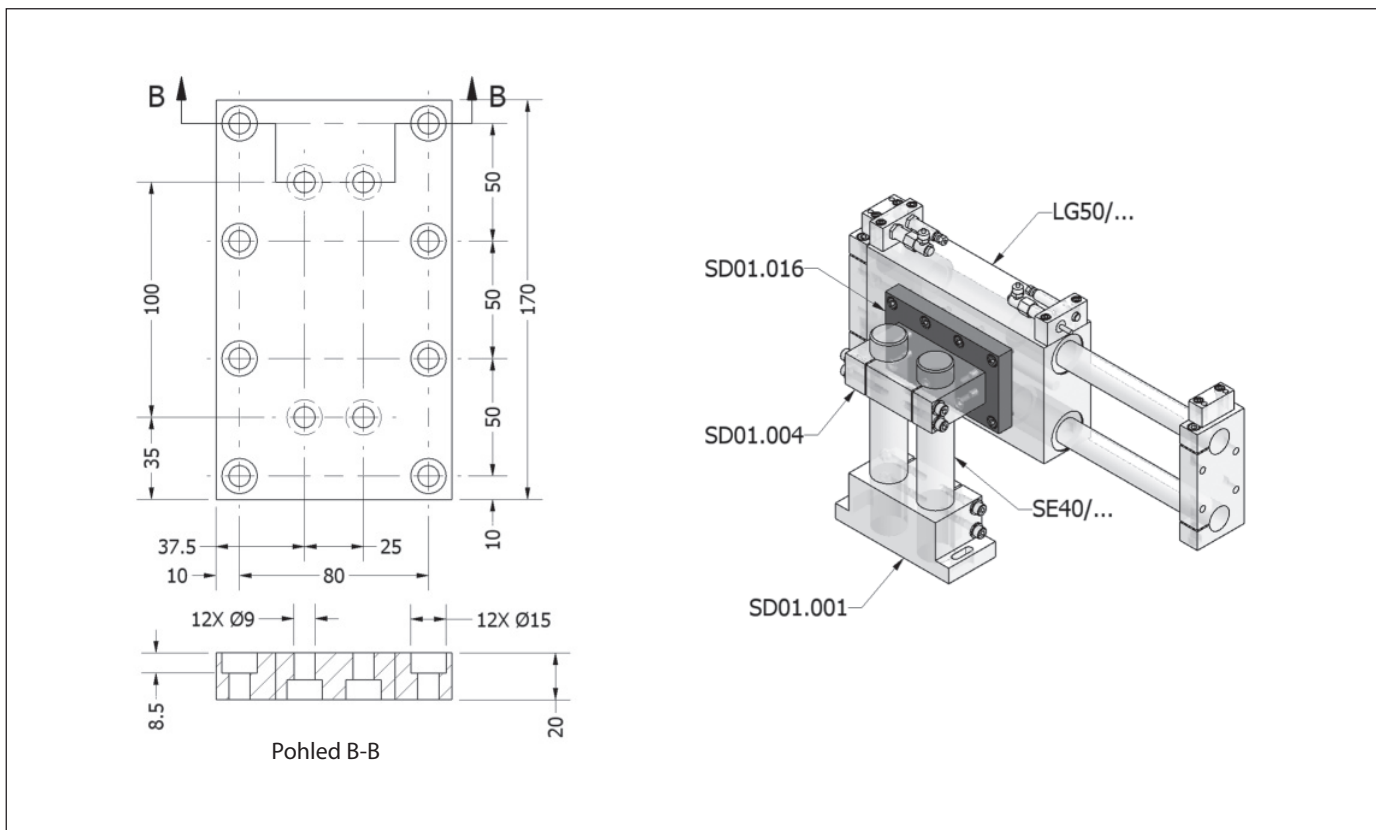

Stojany a montážní držáky - příklady použití



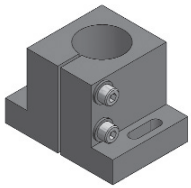
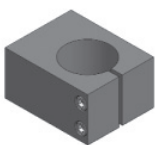
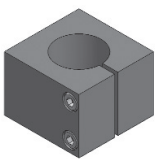

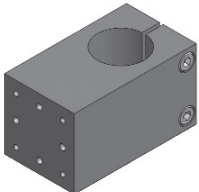
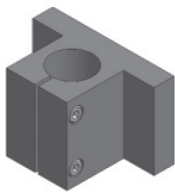
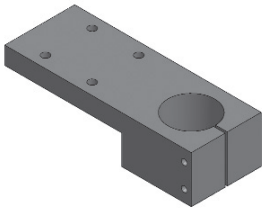
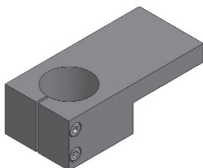

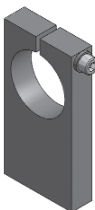
Stojany a montážní držáky - příklady použití

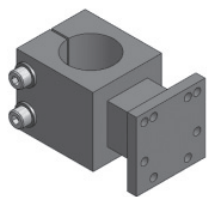
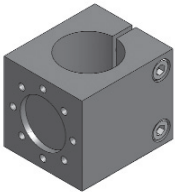
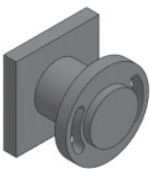
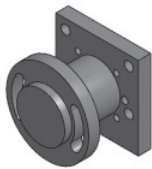
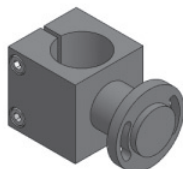
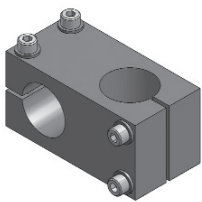
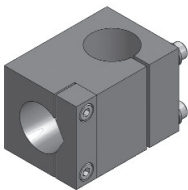
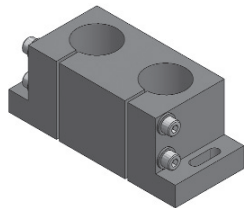
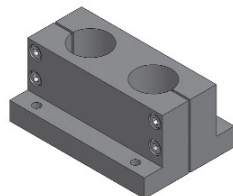
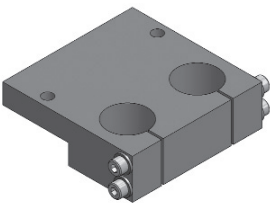
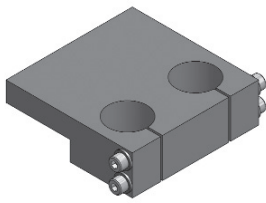
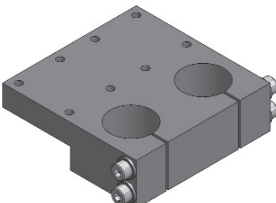
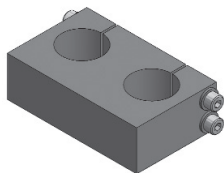

Stojany a modulové montážní držáky a redukční desky

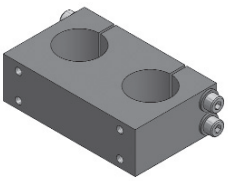
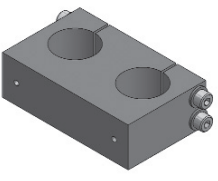
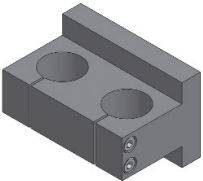
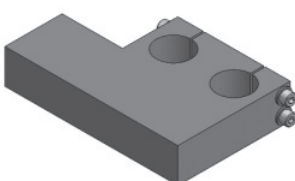
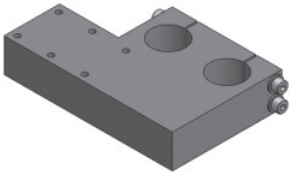
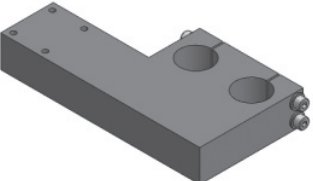
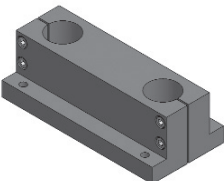
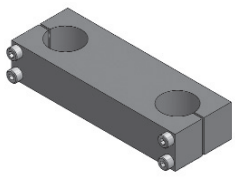
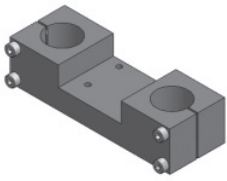
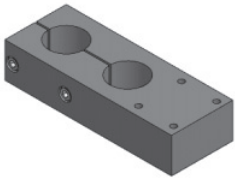
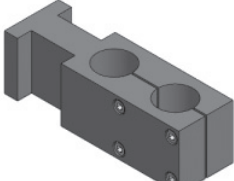
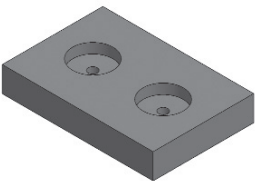
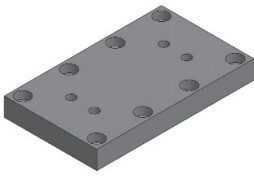
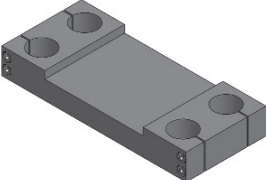
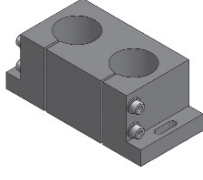
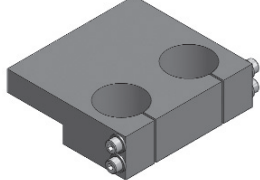
SE01.001 	SE01.017 	SE01.068 	SE01.007 
SE01.060 	SE03.001 	SE01.027 	SE01.008 
SE01.014 	SE01.023 	SE01.024 	SE01.010 
SE01.018 	SE01.055 	SE01.054 	SE01.019 
SE01.003 	SE01.030 	SD01.001 	SD03.001 
SD01.005 	SD01.003 	SD01.002 	SD01.006 

Stojany a modulové montážní držáky a redukční desky

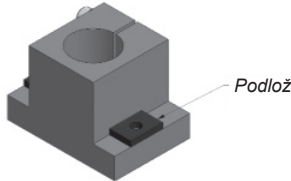
SD01.004 	SD01.013 	SD01.032 	SD01.008 
SD01.009 	SD01.025 	SD01.200 	SD01.201 
SD01.202 	SD01.190 	SD01.011 	SD01.012 
SD01.016 	SE03.300 	SD50.001 	SD50.140 
SE40.300 	SE40.M06 	SE50.300 	N003.008 

Stojany a modulové montážní držáky

Podstavec

Objednací číslo	Rozměr
SE 01.001	100 X 70 mm

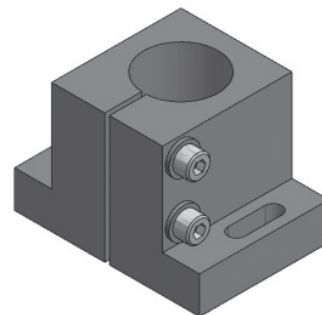
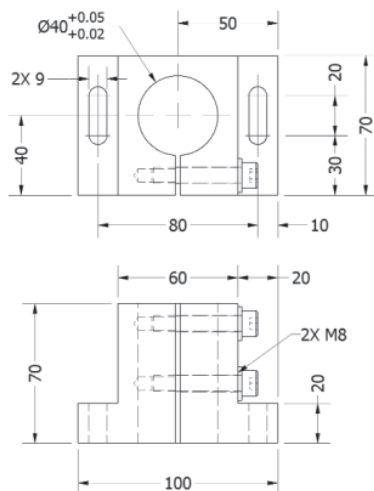

Montážní držák

Objednací číslo	Rozměr
SE 01.017	75 x 60 mm

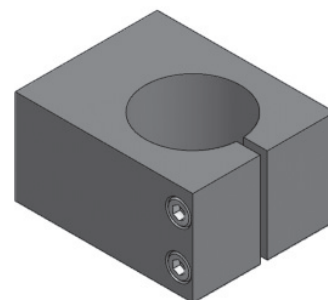
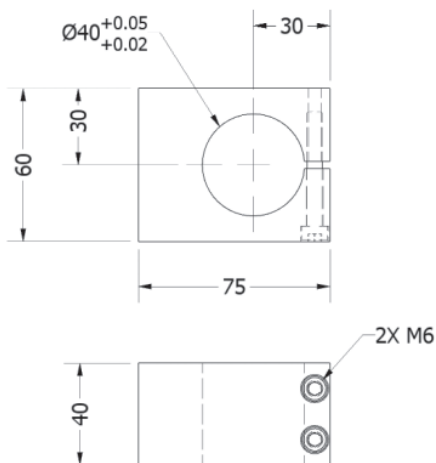

Montážní blok

Objednací číslo	Rozměr
SE 01.068	68 x 68 mm
SE 01.088	88 x 68 mm

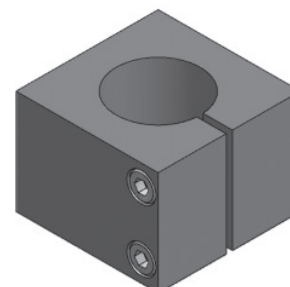
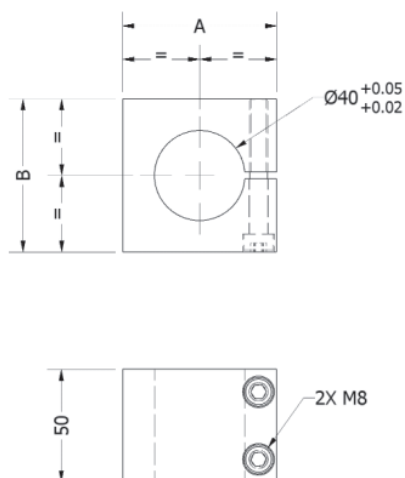

Stojany a modulové montážní držáky

Montážní držák

Objednací číslo	Rozměr
SE 01.007	60 x 60 mm

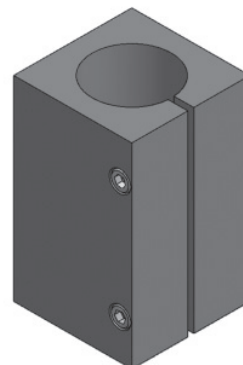
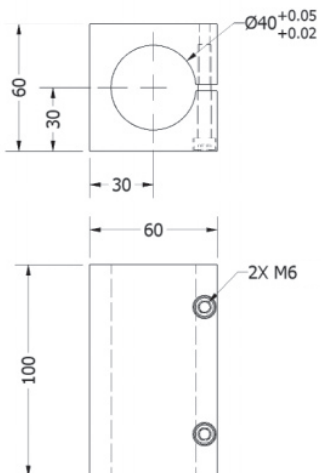

Montážní držák

Objednací číslo	Rozměr
SE 01.060	105 x 60 mm

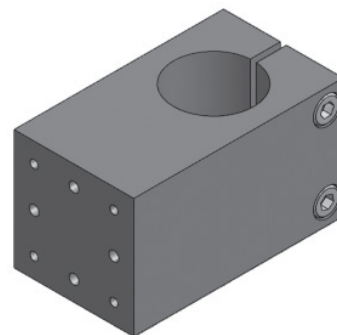
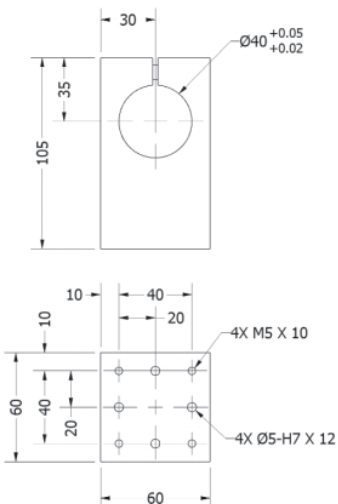

Montážní držák

Objednací číslo	Rozměr
SE 03.001	100 mm
SE 03.002	120 mm
SE 03.003	140 mm

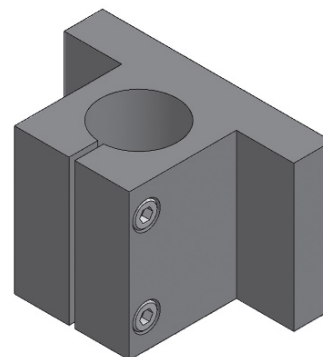
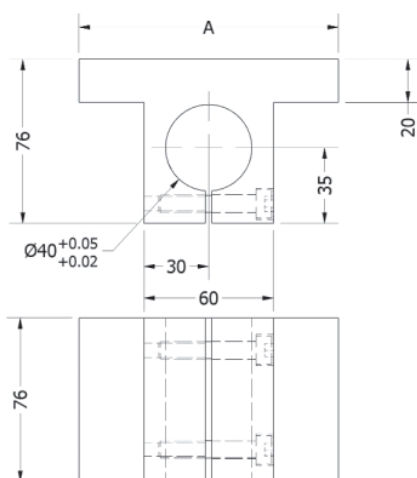

Stojany a modulové montážní držáky

Montážní držák pro ML 26

Objednací číslo	Rozměr
SE 01.027	160 x 60 mm

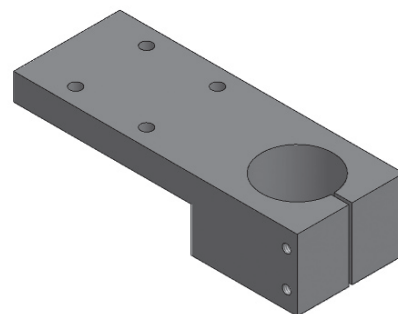
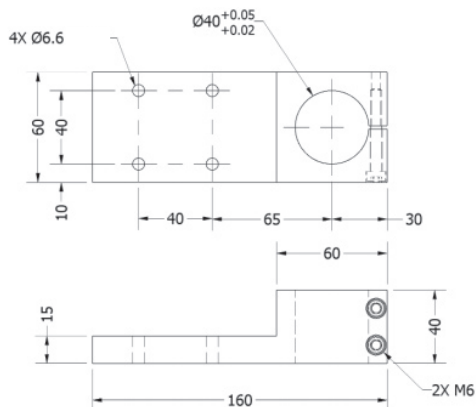

Montážní držák

Objednací číslo	Rozměr
SE 01.008	126 x 60 mm

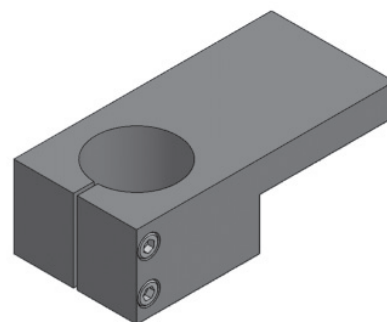
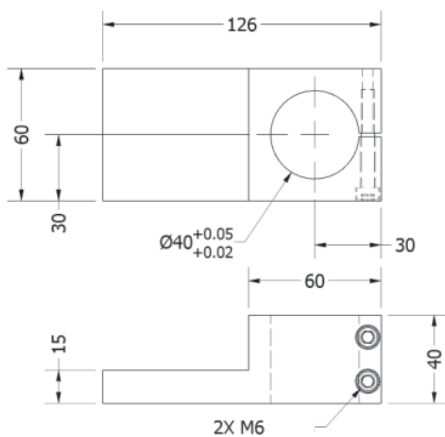

Montážní deska pro KOB 50

Objednací číslo	Rozměr
SE 01.014	160 x 50 mm

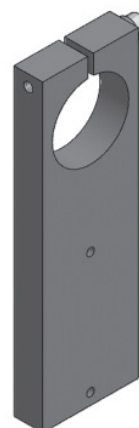
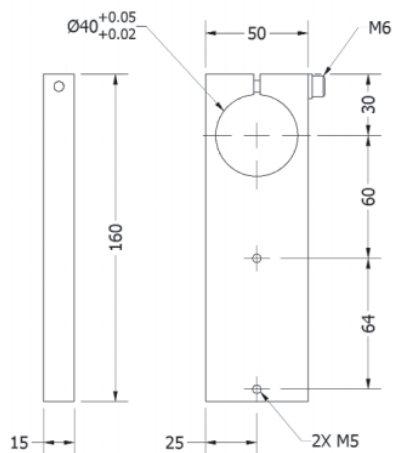

Stojany a modulové montážní držáky

Montážní deska

Objednací číslo	Rozměr
SE 01.023	100 mm
SE 01.022	160 mm
SE 01.021	200 mm
SE 01.020	250 mm
SE 01.012	278 mm

Montážní deska

Objednací číslo	Rozměr
SE 01.024	100 mm
SE 01.025	160 mm
SE 01.026	200 mm

Montážní držák pro VE

Objednací číslo	Rozměr
SE 01.010	105 mm
SE 01.016	180 mm

Stojany a modulové montážní držáky

Držák SE

Objednací číslo	Rozměr
SE 01.018	70 X 60 mm

Technical drawing details:
 - Overall dimensions: 60 mm width, 70 mm height.
 - Top edge: 2X M8 mounting holes.
 - Front face: 8X M6 X 10 mounting holes.
 - Central hole: $\varnothing 40^{+0.05}_{+0.02}$.
 - Bottom edge: $\varnothing 46 @ 45^\circ$ chamfered edge.
 - Front face hole diameter: $\varnothing 35^{+0.05}_{+0.02}$.

Montážní držák

Objednací číslo	Rozměr
SE 01.055	50 x 60 mm

Technical drawing details:
 - Overall dimensions: 50 mm height, 60 mm width.
 - Section A-A: Shows a central hole of $\varnothing 33.5$ mm and a diameter of $\varnothing 60$ mm.
 - Front face: 2X 6.6 mm diameter holes.
 - Chamfered edge: 60° angle, R23 radius.
 - Section A-A label: Pohled A-A.

Montážní držák

Objednací číslo	Rozměr
SE 01.054	50 X 60 mm

Technical drawing details:
 - Overall dimensions: 50 mm height, 60 mm width.
 - Section A-A: Shows a central hole of $\varnothing 33.5$ mm and a diameter of $\varnothing 60$ mm.
 - Front face: 4X M5 holes and 2X 6.6 mm diameter holes.
 - Chamfered edge: $2X 30^\circ$ angle, R23 radius.
 - Section A-A label: Pohled A-A.

Stojany a modulové montážní držáky

Montážní držák

Objednací číslo	Rozměr
SE 01.019	100 x 60 mm

Montážní držák

Objednací číslo	Rozměr
SE 01.003	120 X 60 mm

Montážní držák

Objednací číslo	Rozměr
SE 01.030	160 X 70 mm

Stojany a modulové montážní držáky

Podstavec

Objednací číslo	Rozměr
SD 01.001	170 x 70 mm

Podstavec

Objednací číslo	Rozměr
SD 03.001	140 X 88 mm

Montážní deska pro úhlový nakladač

Objednací číslo	Rozměr
SD 01.005	130 x 130 mm

Stojany a modulové montážní držáky

Montážní deska

Objednací číslo	Rozměr
SD 01.003	130 mm
SD 01.010	160 mm
SD 01.007	200 mm

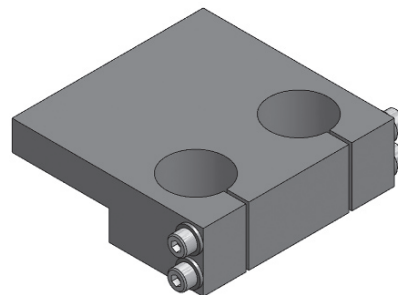
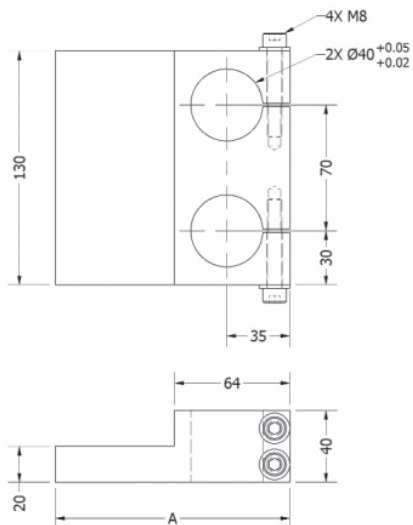

Montážní deska pro LH

Objednací číslo	Rozměr
SD 01.002	130 x 130 mm

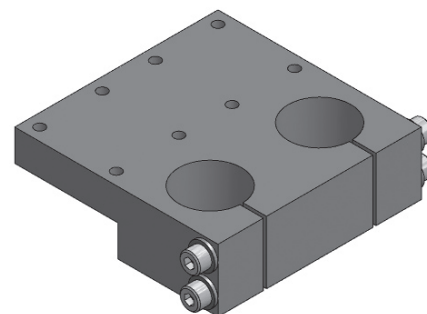
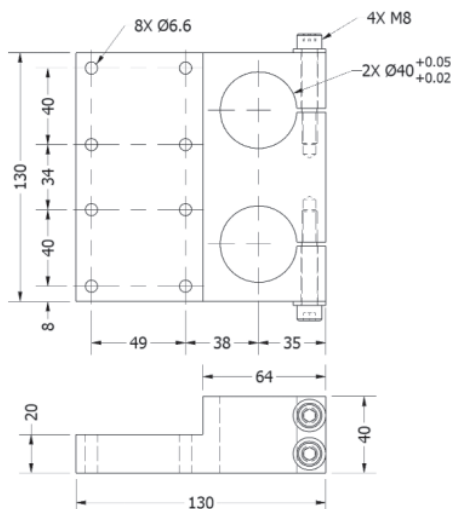

Montážní držák

Objednací číslo	Rozměr
SD 01.006	80 mm
SD 01.060	100 mm
SD 01.066	120 mm

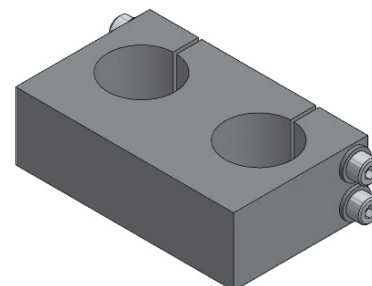
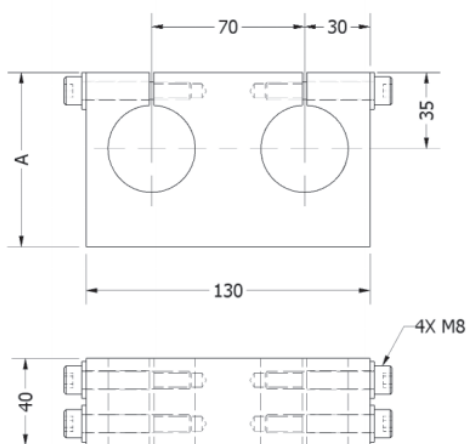

Stojany a modulové montážní držáky

Montážní blok

Objednací číslo	Rozměr
SD 01.004	130 X 80 mm

Montážní držák

Objednací číslo	A	B	C	D	E
SD 01.013					
NT 61	130	30	14.5	101	M6/18
SD 01.014					
NT 120	150	40	8	134	M8/20

Montážní blok

Objednací číslo	Rozměr
SD 01.032	130 x 85 mm

Stojany a modulové montážní držáky

Montážní deska

Objednáací číslo	Rozměr
SD 01.008	130 x 200 mm

Montážní deska

Objednáací číslo	Rozměr
SD 01.009	200 mm

Montážní deska

Objednáací číslo	Rozměr
SD 01.025	130 X 250

Stojany a modulové montážní držáky

Podstavec

Objednací číslo	Rozměr
SD 01.200	204 X 88 mm

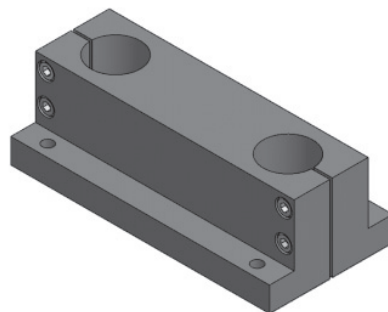
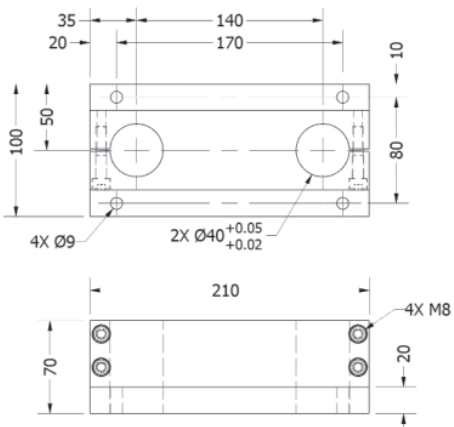

Montážní držák

Objednací číslo	Rozměr
SD 01.201	204 X 70 mm

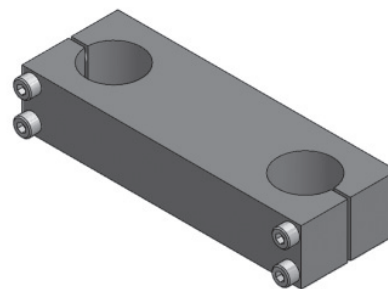
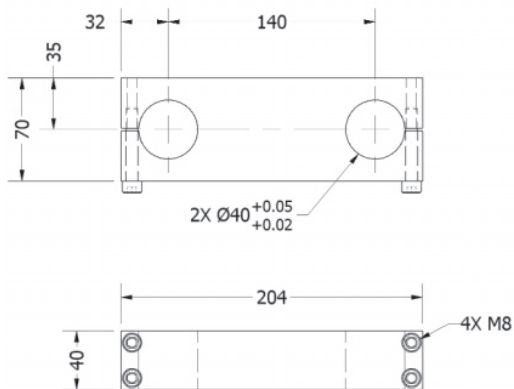

Montážní blok pro LH

Objednací číslo	Rozměr
SD 01.202	204 X 70 mm

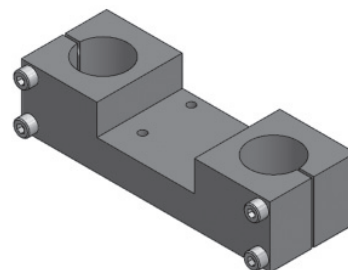
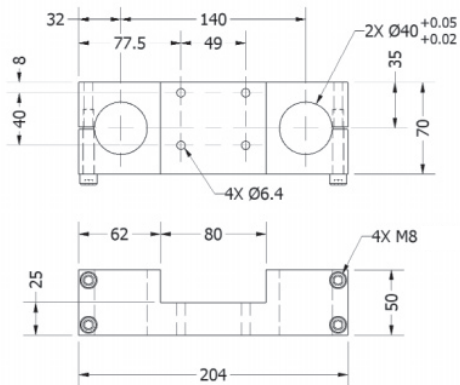

Stojany a modulové montážní držáky

Montážní blok pro LH

Objednáací číslo	Rozměr A
SD 01.190	190 mm
SD 01.220	220 mm
SD 01.250	250 mm

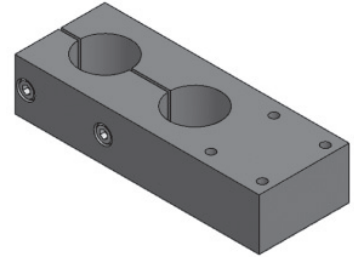
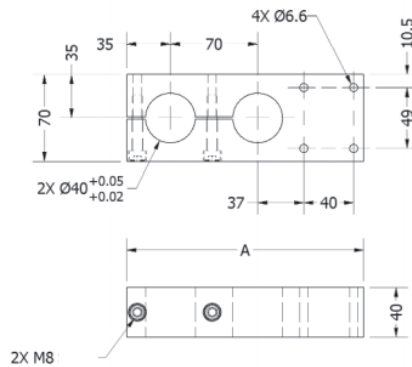

Montážní blok

Objednáací číslo	Rozměr
SD 01.011	200 X 62 mm

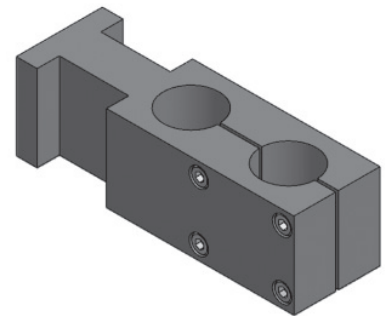
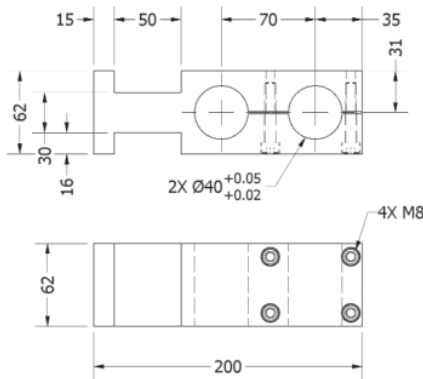

Montážní deska

Objednáací číslo	Rozměr
SD 01.012	150 x 100 mm

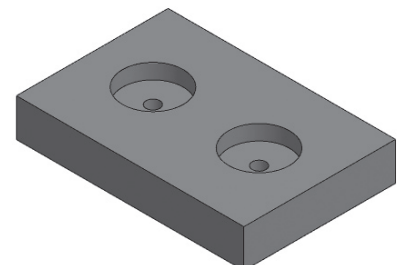
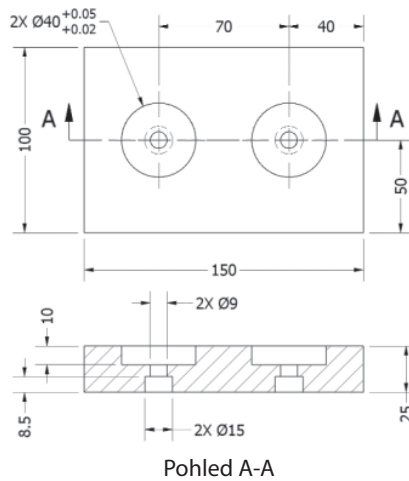

Stojany a modulové montážní držáky

Montážní deska pro LG

Objednací číslo	Rozměr
SD 01.016	170 x 100 mm

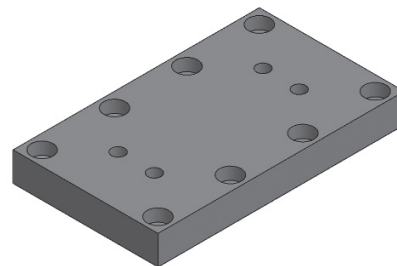
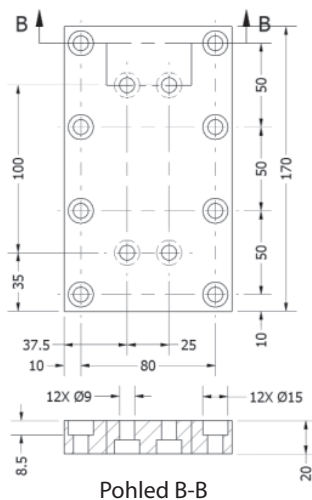

Montážní deska

Objednací číslo	Rozměr	
	A	B
SE 03.300	300 mm	160 mm
SE 03.400	400 mm	260 mm
SE 03.500	500 mm	360 mm

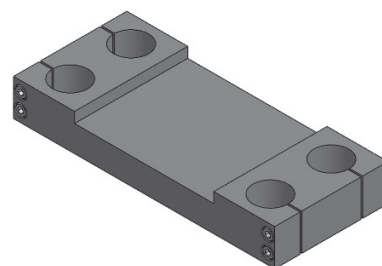
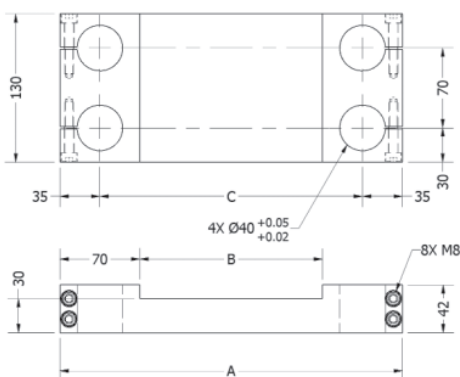

Montážní deska

Objednací číslo	Rozměr
SD 50.001	190 x 88 mm

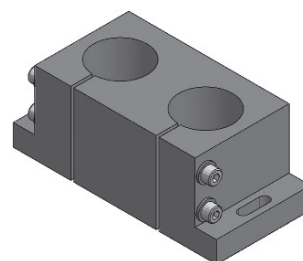
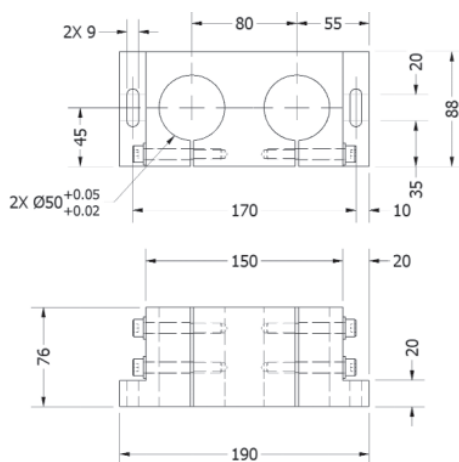

Stojany a modulové montážní držáky

Montážní deska

Objednáací číslo	Rozměr A
SD 50.140	140 mm
SD 50.180	180 mm
SD 50.220	220 mm
SD 50.260	260 mm

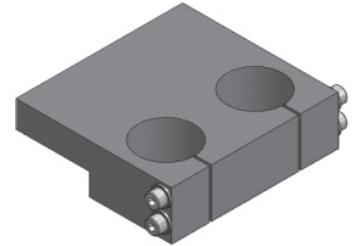
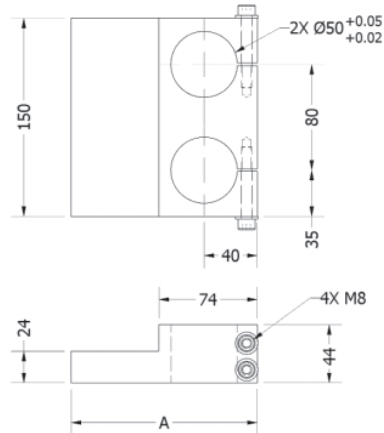

Sloupek

Objednáací číslo	Rozměr
SE 40 x	délka na přání

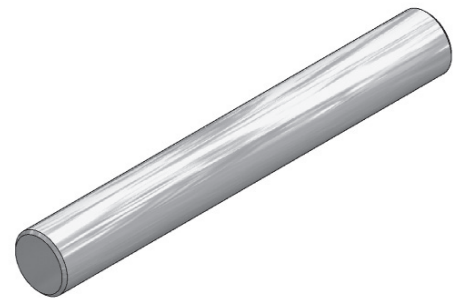
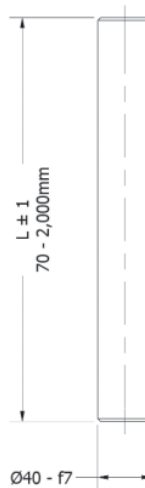

Sloupek s M6, M8, M12

Objednáací číslo	
SE 40M06-	délka na přání
SE 40M08-	
SE 40M12-	

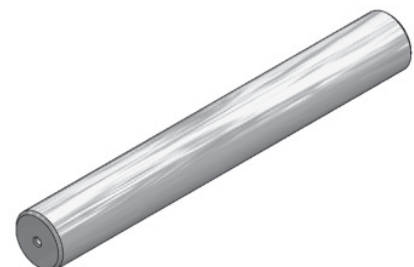

Stojany a modulové montážní držáky

Sloupek

Objednací číslo	L
SE 50 x 300	300 mm
SE 50 x ...	délka na přání

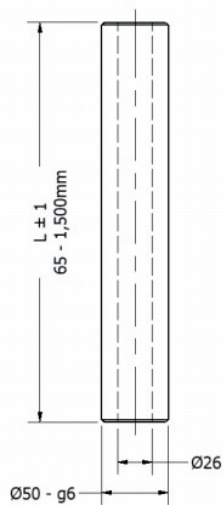

Podložka

Objednací číslo
NO 03.008

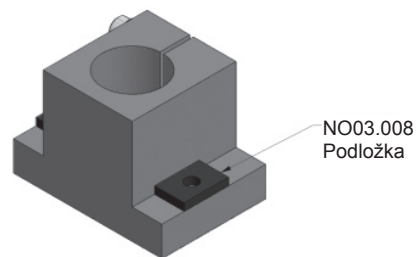
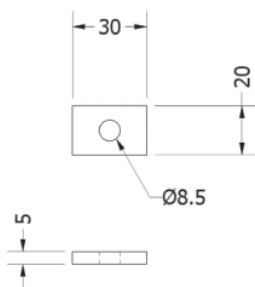

Kulisy

Jednoduchá kulisa

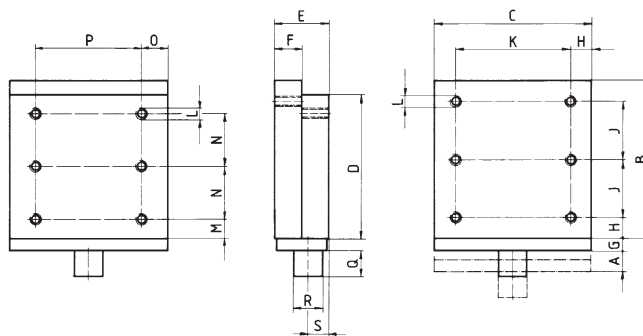
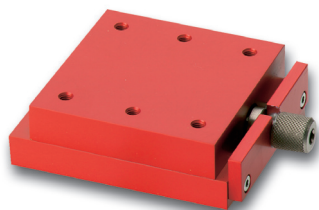

Materiál kulisy: AL Mg Si 1

Typ	A	B	C	D	E	F	G	H	J	K	L	M	N	O	P	Q	R	S	Hmotnost	Obj. č.
40x40	0-12	40	40	35	20	10,5	4	5	15	30	M4	5	12,5	7,5	25	8	9	9,5	0,10 kg	EK 40x40
70x40	0-12	70	40	65	20	10,5	4	5	30	30	M4	5	27,5	7,5	25	8	9	9,5	0,16 kg	EK 70x40
75x75	0-16	75	75	70	26	13	6	10	27,5	55	M5	10	25	12,5	50	12	14	14	0,42 kg	EK 75x75
100x100	0-26	100	100	84	35	17,5	6	10	40	80	M6	12	30	20	60	16	16	19	0,93 kg	EK 100x100
125x125	0-26	125	125	110	35	17,5	8	15	47,5	95	M8	15	40	22,5	80	18	18	17	1,52 kg	EK 125x125
150x150	0-26	150	150	135	35	17,5	8	15	60	120	M8	17,5	50	25	100	18	18	17	2,10 kg	EK 150x150

Křížová kulisa

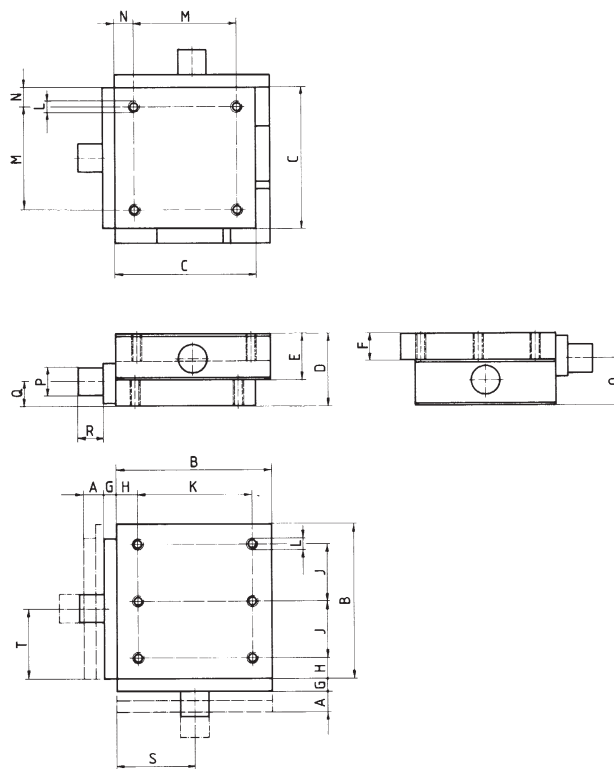
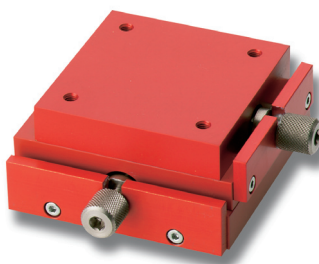

Materiál kulisy: AL Mg Si 1

Typ	A	B	C	D	E	F	G	H	J	K	L	M	N	O	P	Q	R	S	T	Hmotnost	Obj. č.
40x40	0-12	40	35	28	19	10,5	4	5	15	30	M4	25	5	17,5	9	8,5	8	20	17,5	0,13 kg	KK 40x40
75x75	0-16	75	70	35	23	13	6	10	27,5	55	M5	50	10	23	14	12	12	37,5	35	0,58 kg	KK 75x75
100x100	0-26	100	84	49	31,5	17,5	6	10	40	80	M6	60	12	33	16	16	16	50	42	1,28 kg	KK 100x100
125x125	0-26	125	110	55	37,5	17,5	8	15	47,5	95	M8	80	15	37	18	18	18	62,5	55	2,34 kg	KK 125x125
150x150	0-26	150	135	55	37,5	17,5	8	15	60	120	M8	100	17,5	37	18	18	18	75	67,5	3,37 kg	KK 150x150

Poznámka: Kombinační možnosti kulis viz zadní strana

Úhelník

pro kulisy

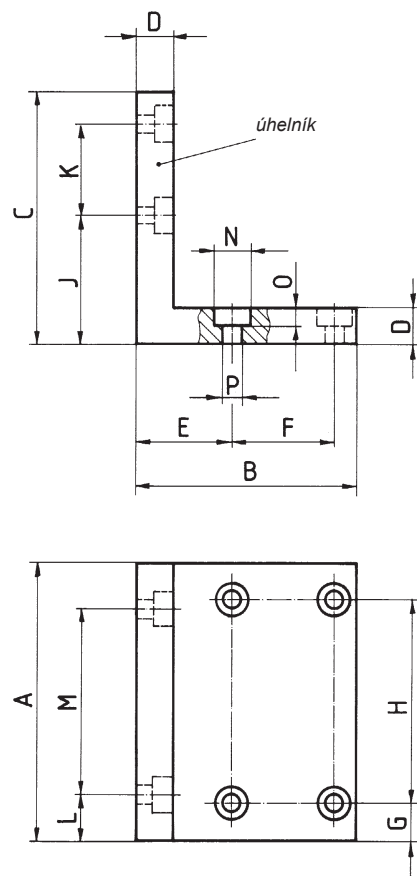
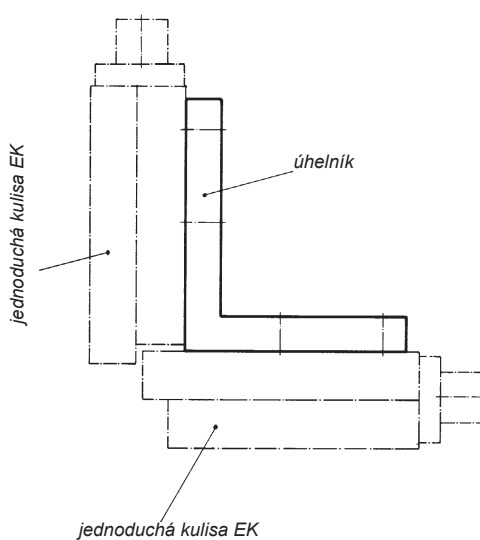
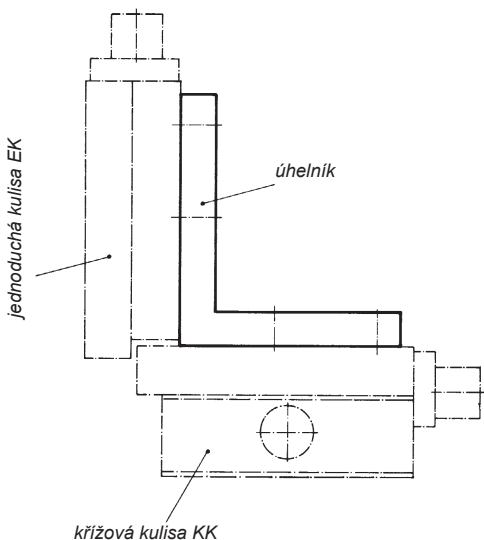
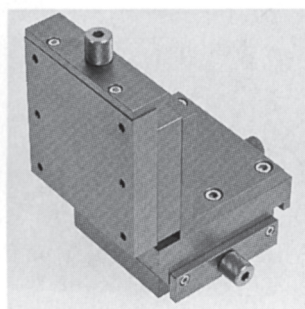

Kulisy	A	B	C	D	E	F	G	H	J	K	L	M	N	O	P	Hmotnost	Úhelník Obj. č.
EK 40x40 / EK 40x40	40	30	35	5	11	15	5	30	18,5	12,5	7,5	25	-	-	4,5	0,03 kg	EK 01.901
KK 40x40 / EK 40x40																	
EK 75x75 / EK 75x75	75	60	70	10	26	27,5	10	55	36,5	25	12,5	50	10	5,2	5,5	0,24 kg	EK 03.901
KK 75x75 / EK 75x75																	
EK 100x100 / EK 100x100	100	82	90	10	34	40	10	80	50	30	20	60	11	6,2	6,6	0,43 kg	EK 04.901
KK 100x100 / EK 100x100																	
EK 125x125 / EK 125x125	125	105	115	15	46,5	47,5	15	95	64	40	22,5	80	15	8,3	9	1,03 kg	EK 05.901
KK 125x125 / EK 125x125																	
EK 150x150 / EK 150x150	150	130	140	18	59	60	15	120	76	50	25	100	15	8,3	9	1,83 kg	EK 06.901
KK 150x150 / EK 150x150																	

Kulisy musejí být objednány samostatně!

Statické zatížení pro kulisy EK a KK

Jednoduchá kulisa	Křížová kulisa	Nosnost F
EK40x40	KK40x40	500N
EK70x40	-	1000N
EK75x75	KK75x75	1500N
EK100x100	KK100x100	2200N
EK125x125	KK125x125	3500N
EK150x150	KK150x150	6000N

